

DROSS CART & DOWNDRAFT TABLE

MEETS OSHA AND EPA EXPOSURE REQUIREMENTS

SMART HANDLING SOLUTIONS



A.

B.

C.



BLISS

INDUSTRIES, INC.

408-945-8401

www.blissindustries.com

DROSS CART & DOWNDRAFT TABLE

MEETS O.S.H.A. EXPOSURE REQUIREMENTS

FEATURES

- Reduces lead fume exposure
 - Meets EPA & O.S.H.A. requirements
 - Contains dross safely
 - Safe and easy solutions for dedrossing and service of wave solder pump
- Custom sizes and features available
See all the options and accessories online
www.blissindustries.com

3 1/2 gallon dross cart with fume cover, ideal to support solder rework area

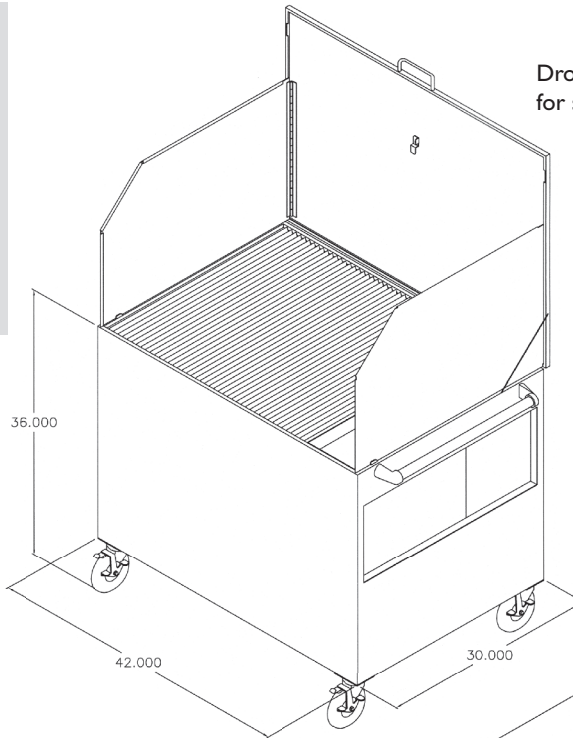
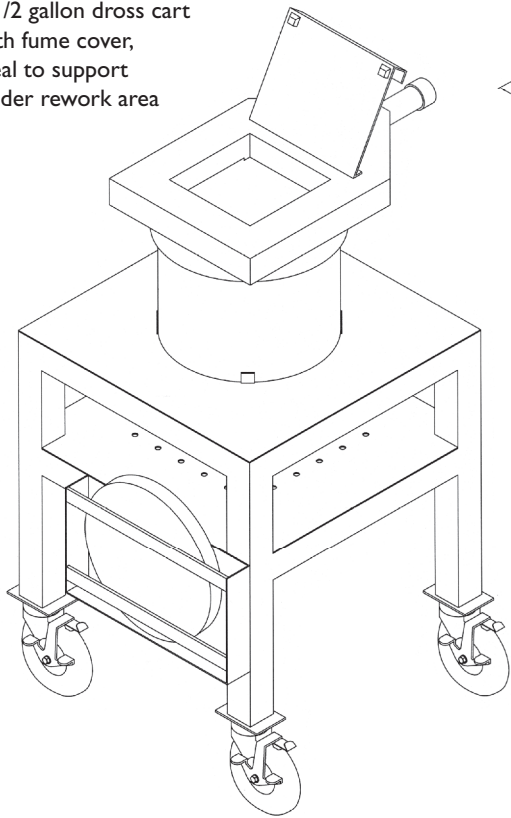

Dross downdraft table/cart for servicing the solder pump

30 gal. dross cart with fume cover ideal to support wave solder machine (vacuum with H.E.P.A. filter sold separately)

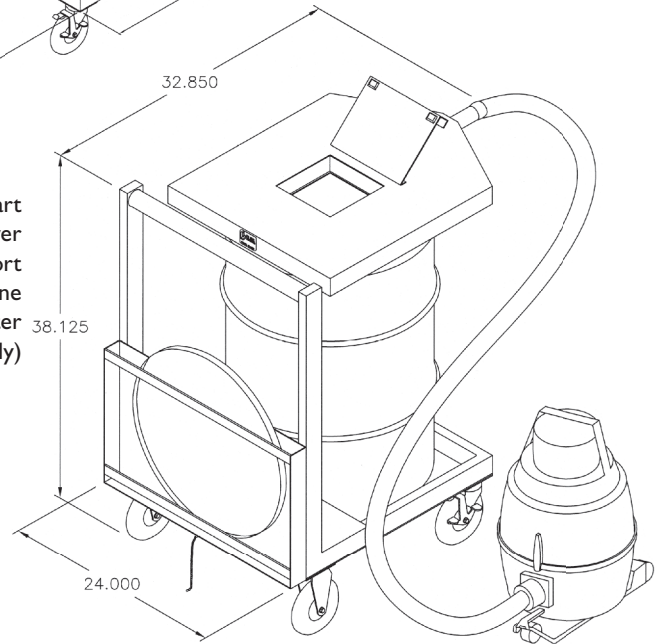

Bliss Industries wave solder support equipment was developed to help reduce employee exposure to hazards related to wave solder machine maintenance, including exposure to lead fume particulates in the air and on work surfaces.

The **Bliss Downdraft Table/Cart** is designed to make servicing of the solder pump and pot from the wave solder machine more efficient. The unit attaches to a H.E.P.A. air purification system which prevents the escape of fumes and particulates into the air.

A Step Towards Lean Manufacturing
Complete details and catalog online



BLISS
INDUSTRIES, INC.

386 Railroad Ct.
Milpitas, CA 95035

Phone: 408-945-8401 • Fax: 408-945-1914

sales@blissindustries.com • www.blissindustries.com

The **Bliss Dross Cart with Fume Cover** is designed to make dedrossing more efficient and eliminates the fumes and particulates that would otherwise escape into the air. The cart provides convenient dross collection from a number of wave solder machines. The baffled fume cover seals the top of the drum and attaches to a vacuum with a H.E.P.A. air purification system that prevents the escape of fumes and particulates. Dross is transferred to the drum through a hinged door in the top cover. The lid for the drum stores conveniently on the cart.